



# UM9169

## Tone Dialer with Redial

ADVANCED PRODUCT DESCRIPTION

### Features

- Wide operating voltage (3.0V – 10.0V)
- Ripple supplied, operating directly from telephone line
- 31-digit memory for redial
- Use TV standard crystal (3.58 MHz) or ceramic resonator resonator
- PABX auto access pause stored in redial memory as one digit number. Auto pause time = 3.6 sec.
- On-chip generation of reference voltage to assure amplitude stability
- Use 4 x 4 or 2 of 8 keyboard

### General Description

The UM9169 DTMF TONE DIALER with redial is specially designed to implement a dual tone telephone dialing system. The device can interface directly to a standard pushbutton telephone keyboard or calculator type XY keyboard and operates directly from the telephone lines. A voltage reference is generated on the chip which is stable under the ripple supplied voltage and regulates the signal levels of the dual tones to meet the recommended telephone industry specifications.

All necessary dual-tone frequencies are derived from the widely used TV standard crystal or 3.58MHz ceramic resonator

which providing very high accuracy and stability. The required sinusoidal waveform for the individual tones is digitally synthesized on the chip. The waveform so generated has very low total harmonic distortion. (less than 1% within voice band).

Auto access pause is available and pause time is 3.6 sec for each [P] key entry. Many times of PAUSE key entry in series can be accepted and stored to redial memory so that multiple pause time can be obtained. Last number up to 31 digits can be redialed with [RD] key which is entered as the first key after OFF HOOK.

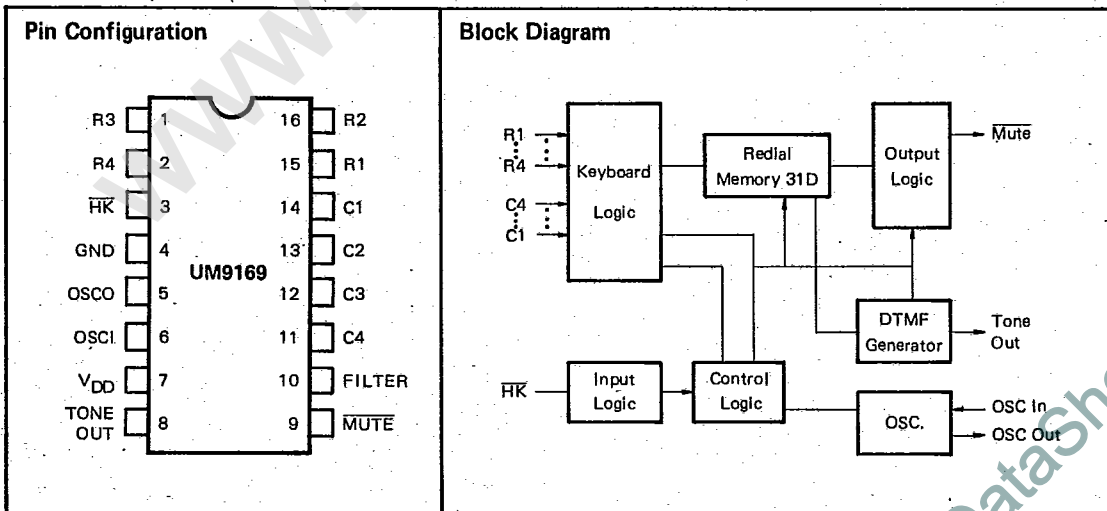

9325812 UNITED MICROELECTRONICS

92D 00409

DT-75-07-07



UM9169

**Absolute Maximum Ratings\***

DC Supply Voltage ( $V_{DD} - V_{SS}$ ) . . . . . -0.3V to 10.5V  
 Operating Temperature ( $T_{Op}$ ) . . . . . -20°C to +60°C  
 Storage Temperature ( $T_{STG}$ ) . . . . . -55°C to +125°C

**\*Comments**

Stresses above those listed under "Absolute Maximum Ratings" may cause permanent damage to the device. This is a stress rating only and functional operation of the device at these or any other conditions above those indicated in the operational sections of this specification is not implied.

**Electrical Characteristics**

(Specifications apply over the operating temperature range of -25°C to +70°C unless otherwise noted. Absolute values of measured parameters are specified.)

Parameter	Symbol	Min.	Typ.	Max.	Units	Conditions
<b>OPERATING VOLTAGE</b>						
Tone Out Mode	$V_{DD}$	3.0		10.0	V	Valid Key Depressed
Memory Retention Voltage	$V_{DD}$	1.2		10.0	V	
<b>OPERATING CURRENT</b>						
Standby Mode	$I_{DD}$			1	$\mu A$	$V_{DD} = 1.2V$ No Key Selected, Tone, MUTE Outputs Unloaded
	$I_{DD}$			10	$\mu A$	$V_{DD} = 10.0V$ No Key Selected, Tone, and MUTE Outputs Unloaded
Operating Mode	$I_{DD}$			4	mA	$V_{DD} = 3.0V$ One Key Selected, Tone, and MUTE Outputs Unloaded
	$I_{DD}$			16.0	mA	$V_{DD} = 10.0V$ One Key Selected, Tone, and MUTE Outputs Unloaded
Single Tone Mode Output Voltage	$V_{OR}$		207		mVrms	$V_{DD} = 3.5V$ Row Tone, $R_L = 1000\Omega$
Ratio of Column to Row Tone	dB <sub>CR</sub>	1.0	2.0	3.0	dB	$V_{DD} = 3.5 - 10.0V$
Distortion	%DIS			1	%	$V_{DD} = 3.5 - 10.0V$
<b>MUTE OUTPUT</b>						
Output Voltage Low	$V_{OL}$		0	0.5	V	$V_{DD} = 3.0V$ , 1 Key Depressed, No Load
	$V_{OL}$		0	0.5	V	$V_{DD} = 10.0V$ , 1 Key Depressed, No Load
Output Voltage High	$V_{OH}$	2.75	3.0		V	$V_{DD} = 3.0V$ , No Key Depressed, No Load
	$V_{OH}$	9.5	10.0		V	$V_{DD} = 10.0V$ , No Key Depressed, No Load
Output Sink Current	$I_{OL}$	0.53	1.3		mA	$V_{DD} = 3.0V$ , $V_{OL} = 0.5V$
	$I_{OL}$	2.0	5.3		mA	$V_{DD} = 10.0V$ , $V_{OL} = 0.5V$

9325812 UNITED MICROELECTRONICS

92D 00410

DT-75-07-07



UM9169

**Key Layout**

1	2	3	
4	5	6	
7	8	9	P
*	0	#	RD

P : PAUSE

RD : REDIAL

**Mute Out ( $\overline{\text{Mute}}$ )**

The mute output ( $\overline{\text{MUTE}}$ ) consists of an open drain N channel device, this output pin is used to control the muting of the telephone network during out dialing.

**Power ( $V_{DD}$ ,  $V_{SS}$ )**

These are the power supply inputs. UM9169 are designed to operate from 3.0 to 10.0 Volts.

**Oscillator Start Voltage ( $V_{DD}$ )**

Type	$V_{DD}$
Crystal	2.5V (max)
Ceramics	3.0V (max)
Oscillator Start Time	10ms (max)

**Keyboard (R1, R2, R3, R4, C1, C2, C3, C4)**

These are 4 row and 4 column inputs from the keyboard contact. On chip pull up resistors (60K $\Omega$ , P-well resistor) held the keyboard input (R1, R2, R3, R4) at high and (C1, C2, C3, C4) are N-ch open drain outputs. When a key is depressed, the oscillator begins oscillating and the dialer identifies the key by examining all four keyboard inputs. When the number is detected, the scanning signal is turned off until next key-in is activated.

**Pin Description**

**Hook Switch Input ( $\overline{\text{HK}}$ )**

This input detect the state of Hook Switch contact. "OFF HOOK" corresponds to  $V_{SS}$  condition. In "ON HOOK" (" $\overline{\text{HK}}$ " = "H"), the row column inputs go into high impedance state, the Oscillator is inhibited and the Mute outputs go into active state ( $\overline{\text{Mute}}$  = "L"), redial memory data is sustained. In "OFF HOOK" ( $\overline{\text{HK}}$  = "L") device normally operates and DTMF generation is enabled after redial key entry.

**Oscillator (OSCI, OSCO)**

UM9169 contains an oscillator circuit with the necessary parastic capacitances and bias resistor on chip so that it is only necessary to connect the standard 3.58MHz TV Crystal or 3.58MHz ceramic resonator with tuning capacitors across the OSCI and OSCO terminals to implement the oscillator function. Oscillation starts with depressing any key entry in "OFF HOOK" and is sustained till DTMF generation is completed.

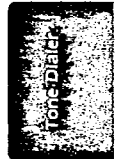

9325812 UNITED MICROELECTRONICS

92D 00411 D 7-75-07-07



UM9169

**Filter & Tone Output**

(Filter/Tone Out)

UM9169 Supports these pins to construct a second order filter structuring by connecting two capacitors obtains low total harmonic distortion (less than 1% at  $V_{DD} = 5V$ ) and intermodulation. The detailed circuit as following:

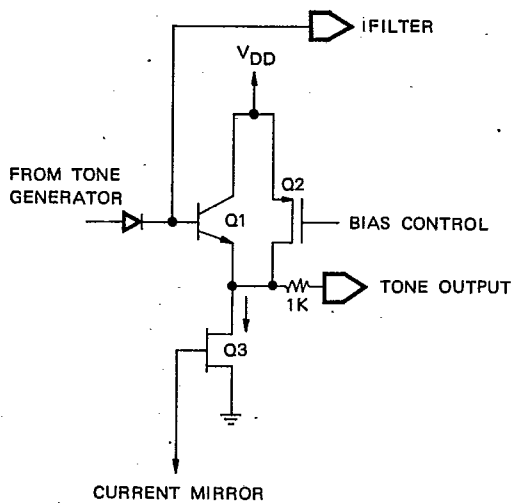

**3. Redialing**

OFF HOOK RD

The Last number, up to 31 digits, can be dialed with RD key entry.

\*If normal dial digit exceeds 31 digits, then, the redial memory would be stored from the 32nd digit to the end.

**4. Memory Cascade. (Redial + Normal Dial)**

OFF HOOK RD -----

(after all DTMF signals are finished)

-- D<sub>1</sub> -- D<sub>n</sub>

OFF HOOK RD

The secondary RD key-in would send out the first redial's digit and the latter N digit (total below 31 digits).

Comparisons of Specified vs Actual Tone Frequencies Generated by UM9169

Active Input	Output Frequency Hz		% Error See Note
	Specified	Actual	
R1	697	699.22	+0.32
R2	770	766.27	-0.48
R3	852	847.54	-0.54
R4	941	948.09	+0.74
C1	1,209	1,215.9	+0.57
C2	1,336	1,331.7	-0.32
C3	1,477	1,471.9	-0.35
C4	1,633	1,645.0	+0.73

Note: % Error does not include oscillator drift.

**Key Operation**

**1. Normal Dialing**

OFF HOOK D<sub>1</sub> ..... D<sub>n</sub>

D = 1, 2, ..., 9, 0, \*, #, pause.

**2. Normal Dialing with Auto Access Pause**

OFF HOOK O P D<sub>1</sub> ..... D<sub>n</sub>

Auto access pause is available and pause 3.6 seconds for each P key entry. Multiple pause key entry can be executed at normal dialing and redialing.